

SECTION 6D

MANUAL TRANSMISSIONS

CONTENTS OF THIS SECTION

	<i>Page</i>
Corvaire—500, 700 and 900 Series	
Three Speed Transmission	6D-1
Four Speed Transmission	6D-15
Corvaire 95 and Greenbrier—1200 Series	
Three Speed Transmission	6D-27
Four Speed Transmission	6D-27

CORVAIR—500, 700 AND 900 SERIES

THREE SPEED TRANSMISSION

INDEX

	<i>Page</i>		<i>Page</i>
General Description	6D-1	Inspection and Repair	6D-7
Maintenance and Adjustments	6D-3	Bearings	6D-7
Lubrication	6D-3	Transmission Case	6D-7
Shift Linkage Adjustment	6D-3	Gears	6D-7
Service Operations	6D-3	Reverse Idler Gear Bushings	6D-7
Service Reference Guide	6D-3	Countergear Needle Bearings	6D-7
Service Operations—Transmission in Vehicle	6D-3	Clutch Gear Bearing Replacement	6D-7
Gearshift Lever Assembly	6D-3	Clutch Sleeve & Synchronizer Rings	6D-8
Shift Control Rod	6D-4	Synchronizer Energizing Springs	6D-10
Transmission Removal and Installation	6D-5	Assembly of Transmission	6D-10
Service Operations—Power Train Removed from Vehicle	6D-5	Troubles and Remedies	6D-13
Disassembly of Transmission	6D-5	Specifications	6D-14

GENERAL DESCRIPTION

The following major changes are incorporated in the 1961 Corvaire three speed transmission:

- Transmission case now cast alloy iron
- Gear ratios revised for greater torque multiplication
- Mainshaft lengthened for improved durability
- Transmission case redesigned to incorporate concentricity pilot in rear face.

In essence, the Corvaire manual three speed transmission is a conventional synchromesh type except for the use of concentric input and output shafts and its mounting on the differential carrier (fig. 6D-1).

Because of its attachment to the differential carrier, the main shaft is hollow to permit passage of the clutch shaft to the front of the transmission to the clutch gear. The clutch gear drives a counter gear and the remaining power flow sequence is identical to the conventional three speed transmission.

Gear ratios are 3.50:1 in first, 1.99:1 in second, and 1:1 in third. Reverse ratio is 3.97:1. The increased multiplication in first and second offsets the reduced rear

axle ratio of 3.27:1 so that total torque multiplication (transmission times rear axle) remains virtually unchanged in the first two gears.

The shift mechanism used is basically a single shift rod system. From the transmission, the single shift rod is connected by a rubber sleeve coupling to the main shift rod which is mounted in the tunnel by two nylon bushed brackets. A 90-degree ball socket is integral to the front of the tunnel shaft which receives the ball-end of the gearshift lever, which is floor mounted in the passenger compartment. By this arrangement, the shift rod can be moved both fore-and-aft and laterally.

In the transmission, the shift rod carries a finger which extends upward to engage either the first and reverse fork or the second and third fork, depending on shift lever position. As the two forks are parallel to each other, a slight rotational motion of the shift rod places the actuating finger in the proper fork and permits the desired shift. An interlock between the two fork shafts holds the fork not being actuated in the neutral cross-over position.

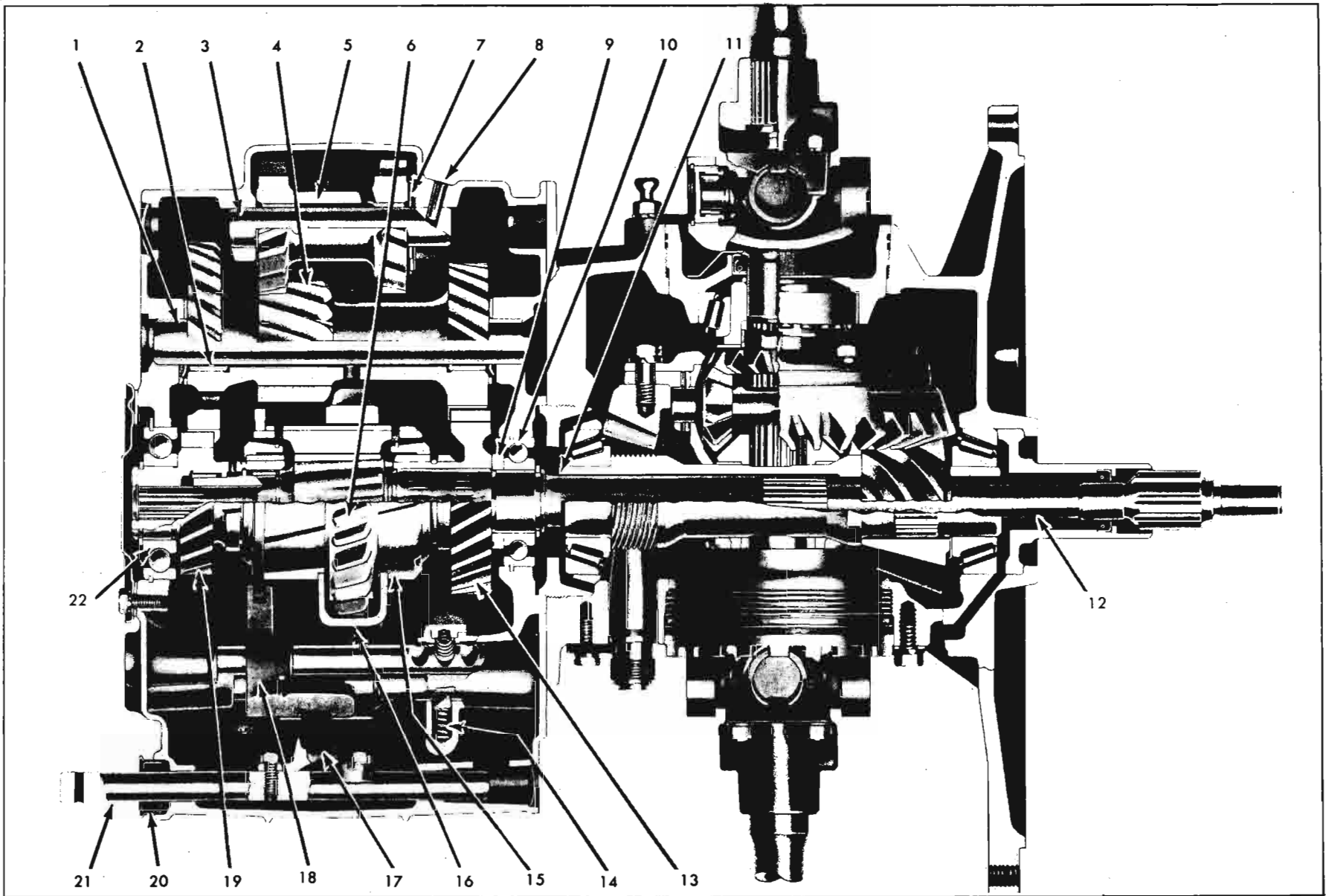

Fig. 6D-1—Three Speed Transaxle—Cross Sectional View

- | | | | |
|-----------------------------------|---------------------------------------|--|---------------------------------------|
| 1. Countergear Shaft | 7. Radial Needle Bearing (Torrington) | 12. Clutch Shaft | 18. Second and Third Speed Shift Fork |
| 2. Countergear Needle Bearings | 8. Reverse Idler Shaft Retaining Pin | 13. Second-speed Gear | 19. Clutch Gear |
| 3. Reverse Idler Gear Shaft | 9. Thrust Washer | 14. First and Reverse Detent Spring and Ball | 20. Manual Shift Shaft Seal |
| 4. Countergear | 10. Mainshaft Bearing | 15. Second and Third Speed Clutch | 21. Manual Shift Shaft |
| 5. Reverse Idler Gear | 11. Mainshaft | 16. First and Reverse Shift Fork | 22. Clutch Gear Bearing |
| 6. First and Reverse Sliding Gear | | 17. Manual Shift Shaft Finger | |

MAINTENANCE AND ADJUSTMENTS

LUBRICATION

Common lubricant, SAE 80, Multipurpose Gear Lubricant, is used in the manual three speed transmission and differential carrier so no oil seals are used between these units. Actually there is some interchange of lubricant but a lubricant dam is formed at the transmission which prevents entrapment of excess lube in the carrier sump which is below the transmission level and maintain transmission lubrication on grades.

Oil Level Check

Each 1000 miles, check the lubricant of the three speed Transaxle by removing the filler plug in the differential carrier. If oil is at the level of carrier filler plug, both the carrier and transmission lubricant levels are satisfactory. If oil is below filler plug, add oil to the carrier as required, then check the lubricant level in the transmission by removing its filler plug. Replenish as necessary.

CAUTION: Under no circumstances should any lubricant containing active sulphur be used. Also, do not use mineral oil. Only SAE 80 Multipurpose gear lubricant should be used.

Oil Change

At the end of the first 1000 miles and each 10,000 miles thereafter (oftener under severe dust or service conditions), drain both the differential carrier and

three speed transmission by removing the drain plug provided in each. Reinstall the drain plugs and refill each unit to the level of the filler plugs with SAE 80 Multipurpose Gear Lubricant.

Complete refills require a total of 4.9 pints lubricant (approximately 2½ pints for each unit).

SHIFT LINKAGE ADJUSTMENT

After any service operation in which the shift control rod in the tunnel has been replaced or it has been found that transmission response is improper to the shift pattern, adjust the shift linkage.

It should be noted that the "Corvaire" shift lever position can be "tailored" to the customer. For example, if the customer is tall and drives with the seat full rearward, the shift linkage can be adjusted so as to minimize the reach for second and reverse by adjusting the linkage as follows with the seat in the customer's normal driving position:

1. Shift the transmission to first, then loosen the coupling clamp nut (fig. 6D-3) on the transmission shift shaft.
2. Move the gearshift lever rearward in first until it is resting against the edge of the seat, then tighten the coupling clamp nut. The shift lever will not touch when a person's weight is on the seat and it should also be noted that the shift throw is longer from neutral to first than neutral to third.
3. Test shifts in all ranges.

SERVICE OPERATIONS

SERVICE REFERENCE GUIDE

All service operations relative to the three speed transmission should be performed with the transmission removed from the vehicle and separated from the power train.

Transmission controls can be serviced without disturbing the power train and therefore are listed under "Service Operations—Transmission In Vehicle" immediately following.

SERVICE OPERATIONS—TRANSMISSION IN VEHICLE

GEARSHIFT LEVER ASSEMBLY

Removal from Vehicle

1. Remove tunnel front plate.
2. Remove four nuts securing gearshift lever assembly to floor pan.

NOTE: Two nuts also secure the shift control shaft front mounting bracket. On early production vehicles, the two rear nuts retain the bracket; on later vehicles, the two front nuts will retain the bracket.

3. From the driver's compartment, lift the gearshift lever assembly up until its studs clear the floor pan, then remove the unit by lifting the floor mat at the center of seat.

Disassembly of Gearshift Lever Assembly

Refer to Figure 6D-2.

1. Unscrew the knob to remove, then clamp the gearshift housing in a vise.
2. Using a length of 1½" pipe or J-5590, depress the retainer plate and rotate until its three lugs clear

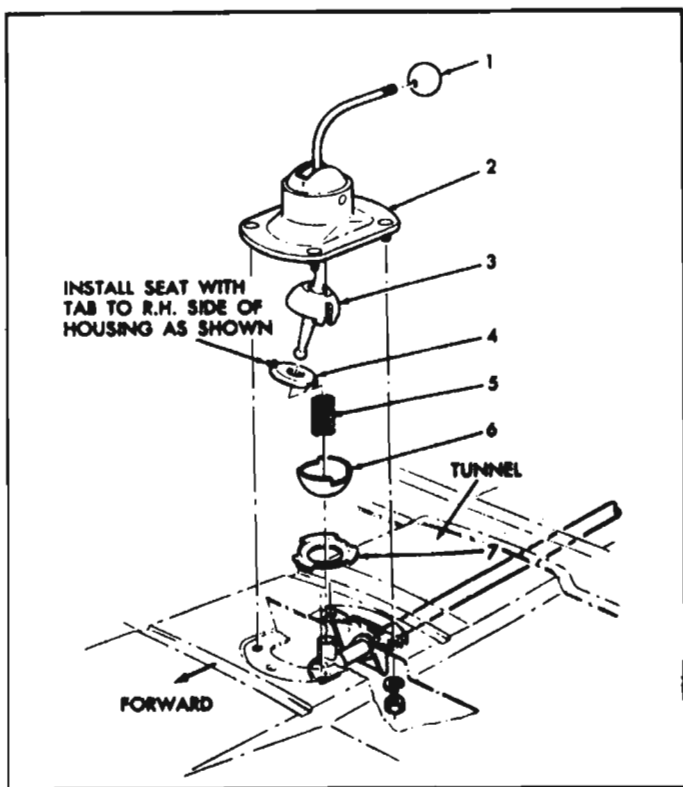

Fig. 6D-2—Gearshift Lever Assembly—Exploded View

- | | |
|--------------------------|--------------------|
| 1. Knob | 5. Spring |
| 2. Housing | 6. Spherical Joint |
| 3. Gearshift Lever Assy. | 7. Retainer |
| 4. Seat | |

the lands in the gearshift housing, then remove the retainer.

- Remove the lower spherical joint, spring, and seat, then pull lever out of housing.

Inspection and Repair

Inspect all working surfaces for wear and roughness. Repair or replace pieces as required. If broken, replace the spring.

Assembly of Gearshift Lever Assembly (fig. 6D-2)

- Apply Lubriplate generously to all working surfaces.
- Place retainer plate on lower spherical and place the housing in a vise.
- Place seat on gearshift lever with tab to right side of housing.
- Place spring and lower spherical joint on seat in housing.
- Place retainer plate on lower spherical joint, then compress the retainer and rotate laterally to engage its lugs in the housing with a length of 1½" pipe or J-5590 if available.
- Complete assembly by installing knob on shift lever.

SHIFT CONTROL ROD

Removal of Control Shaft from Vehicle

- With tunnel cover removed, fold back rubber boot (fig. 6D-3) covering control shaft oil seal at transmission end of shaft sufficiently to expose the connecting pin.

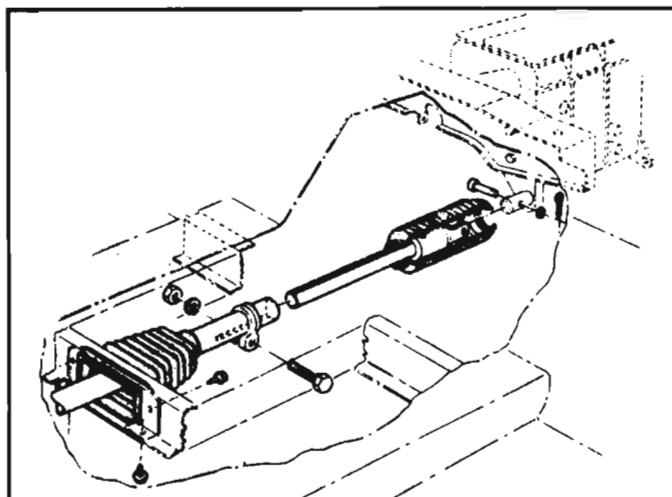

Fig. 6D-3—Tunnel Shaft Components—Exploded

- To remove connecting pin, first remove cotter then remove pin by pushing out with channel lock pliers.
- Separate the control shaft coupling from the transmission shifter shaft by pushing the control shaft toward the front of the car.
- Complete removal of control shaft by removing two nuts attaching control shaft front mounting bracket, then remove control shaft, coupling, and mounting bracket as an assembly.

Inspection and Repair

Coupling Replacement

- To insure maintaining shift control adjustment, scribe the control shaft adjacent to the end of the coupling, then loosen the clamp bolt and remove old coupling and rubber boot.
- Insert new coupling with rubber boot installed in shift control shaft until the end of the coupling is aligned with the mark scribed in Step 1. Rotate coupling so attaching pin hole at transmission end is vertical, then tighten clamp bolt.

Control Shaft Front Mounting Bracket or Bushing Replacement

- Remove the coupling as previously described.
- Slide bracket (fig. 6D-2) off control shaft. Nylon bushing in bracket is of the push-in type.
- Reinstall bracket with reinforced side toward rear of shaft, then install U-joint as previously covered.

Installation of Control Shaft in Vehicle

1. Center the shift lever ball, position and align the control shaft front bracket with the shift lever studs (rear on early vehicles, front on later vehicles), then insert the bracket on its studs simultaneously with insertion of the control shaft ball socket onto the shift lever ball (fig. 6D-2). The control shaft socket should be well coated

- with Lubriplate prior to installation in vehicle.
2. Secure shaft bracket with two nuts.
3. Align control shaft coupling with transmission shifter shaft, then pull coupling over shifter shaft and install connecting pin and secure with cotter pin. Cover with boot (fig. 6D-3).
4. Snap boot of shifter shaft seal into place in tunnel rear plate and install tunnel covers.

TRANSMISSION REMOVAL AND INSTALLATION

Instructions for the removal of the power train from the vehicle and the separation of the transmission from

the power train are provided in Section 6.

SERVICE OPERATIONS—POWER TRAIN REMOVED FROM VEHICLE

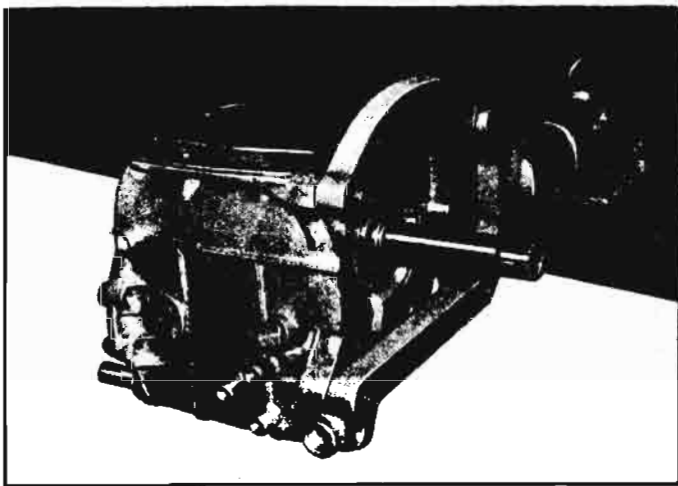

Fig. 6D-4—Transmission in Fixture J-7896

DISASSEMBLY OF TRANSMISSION

1. Mount transmission in holding fixture J-7896 (fig. 6D-4).
2. Remove the front cover plate by removing four bolts and lockwashers, then remove clutch gear bearing snap ring.
3. Remove the clutch gear and bearing with J-8361 as follows:
 - a. Disassemble J-8361 and install the adapter and screw assembly (fig. 6D-5) in slot in clutch gear hub.
 - b. Place dome over adapter and screw, being sure to index dome locating pins into screw holes in transmission case.
 - c. Loosen screws securing bearing snap ring fingers on dome assembly, place fingers between open ends of snap rings, then fully open snap ring with pliers (fig. 6D-6) and tighten finger screws to retain ring fully expanded.

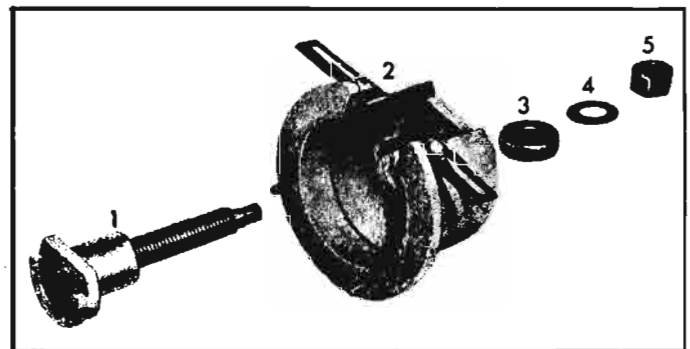

Fig. 6D-5—Clutch Gear Puller J-8361 Components

- | | |
|----------------------------|-----------|
| 1. Adapter and Screw Assy. | 5. Washer |
| 2. Dome and Fingers | 6. Nut |
| 3. Bearing | |

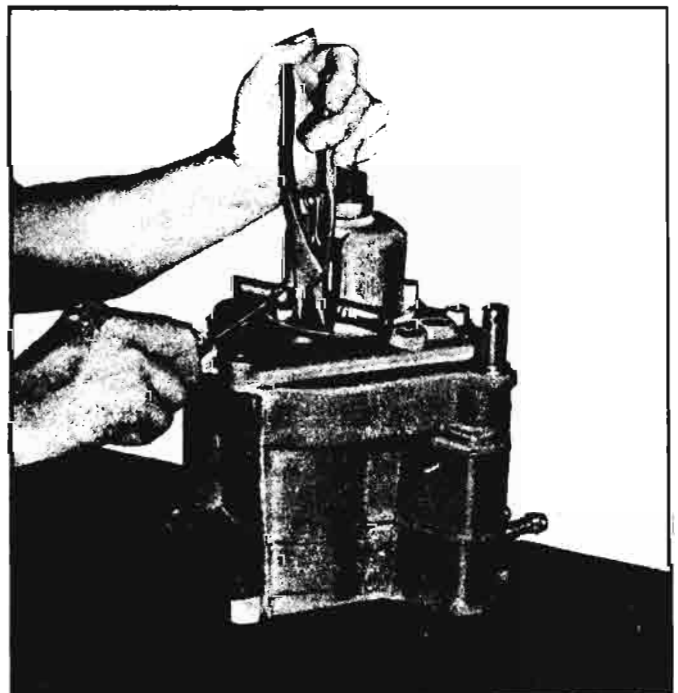

Fig. 6D-6—Locking Clutch Gear Retainer Expanded with J-8361

CAUTION: Before opening snap ring, be sure ends are fairly well centered in recess in case. If ring is expanded when the ring ends are against either side of the recess, the snap ring radius can "hang" in the bearing groove and result in a broken case when the bearing is pulled.

- d. Pull bearing and clutch gear by turning nut while holding screw with a wrench as shown (fig. 6D17). Needle roller bearings will fall out when clutch gear is removed.
4. Remove transmission case top cover and gasket by removing eight screws and lockwashers.
5. Remove snap ring from mainshaft groove. Snap ring is immediately behind mainshaft bearing as shown in figure 6D-1.
6. Drive or press mainshaft out of transmission (fig. 6D-8).
7. Remove thrust washer, second speed gear, sliding gear, and second and third speed clutch from case by lifting out through top cover hole.
8. To remove the mainshaft bearing from the case, fully expand its snap ring and tap bearing out by driving on outer race (fig. 6D-9).
9. Remove countergear by driving out countershaft with J-5777 from the hole in the front of the case. A drift may be used instead of J-5777 but the

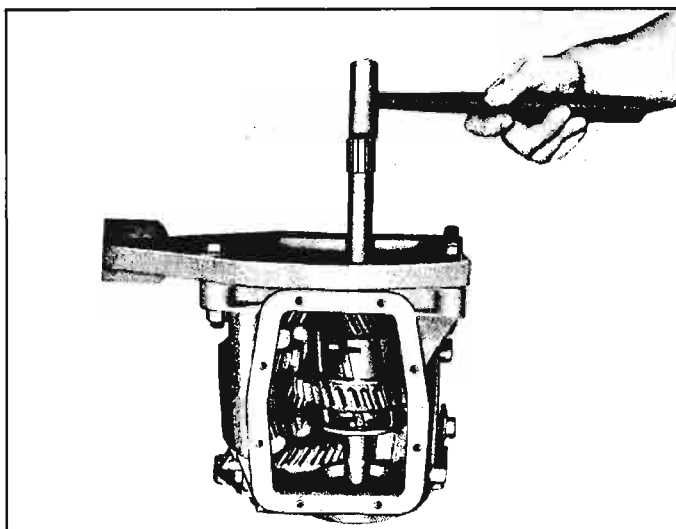

Fig. 6D-8—Driving Mainshaft from Transmission

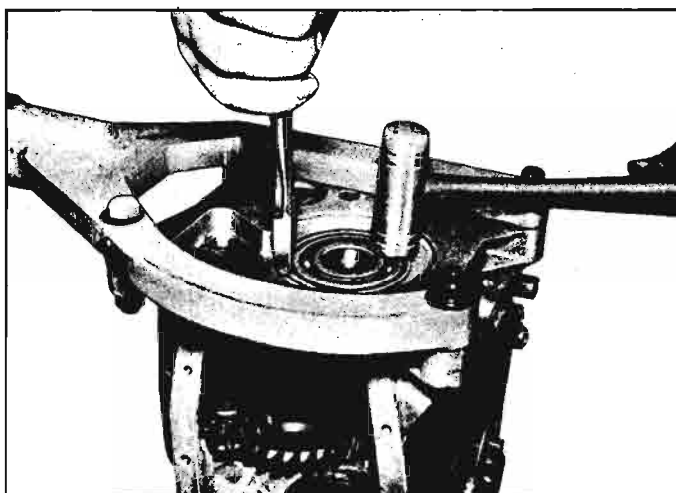

Fig. 6D-9—Removing Mainshaft Bearing from Case

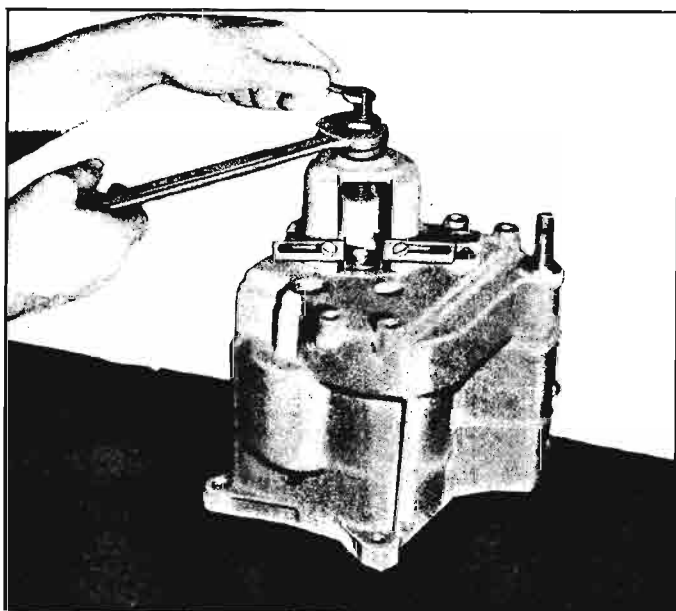

Fig. 6D-7—Pulling Clutch Gear and Bearing with J-8361

needle bearings used at both ends of the countergear will be displaced which will require their restacking at assembly.

10. If replacement is anticipated, remove reverse idler gear. To remove, first drive the reverse idler shaft lock pin into the shaft, then drive the reverse idler shaft out of case with a drift from the hole at the rear of case (fig. 6D-10). The expansion

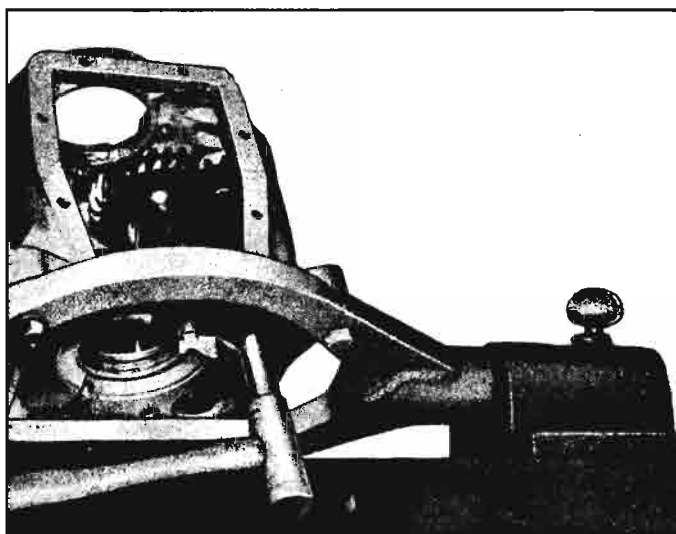

Fig. 6D-10—Removing Reverse Idler Gear

plug at the front of the case will be driven out by the reverse idler shaft. Remove the caged needle bearing and the thrust washer used at the rear of the reverse idler.

11. Remove detent cover and remove second and third gear detent spring and ball.
12. Drive out roll pin securing second and third shift fork (fig. 6D-11) to shaft, then tap out shaft with a drift to remove both fork and shaft.

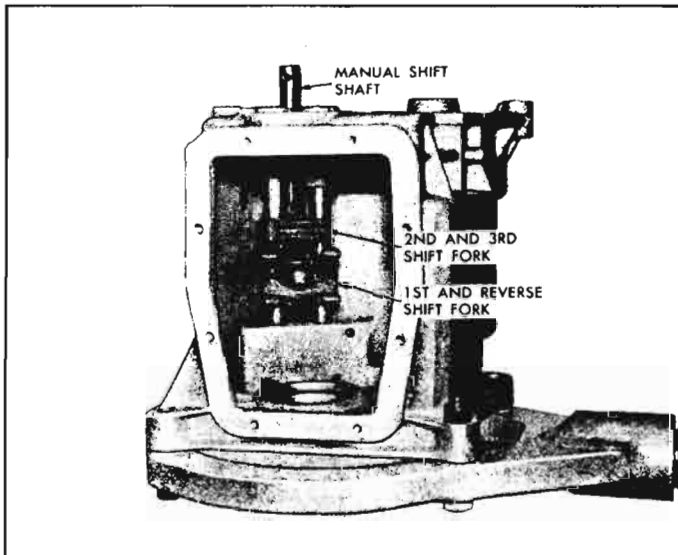

Fig. 6D-11—Shift Forks Installed

13. Remove interlock from detent cavity with a magnet.
14. Remove first and reverse shift fork and shaft in the same manner as the second and third fork.
15. Remove first and reverse detent ball and spring.
16. Complete disassembly by removing two capscrews and lock tabs securing shift finger (fig. 6D-12) to manual shift rod, then pull rod from case.

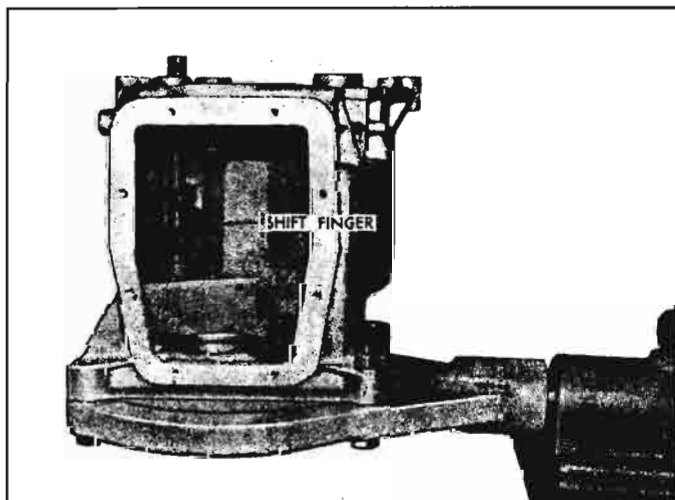

Fig. 6D-12—Manual Shift Rod Finger Installed

All transmission components are shown in Figure 6D-13.

INSPECTION AND REPAIR

Bearings

1. Wash the bearings thoroughly in a cleaning solvent.
2. Blow out the bearings with compressed air.

CAUTION: Do not allow the bearings to spin, but turn them slowly by hand. Spinning bearings will damage the race and balls.

3. After making sure the bearings are clean, lubricate them with light engine oil and check them for roughness. Roughness may be determined by slowly turning the outer race by hand.

Transmission Case

Wash the transmission case inside and outside with a cleaning solvent and inspect for cracks. Inspect the faces for burrs and if any are present, dress them off with a fine cut mill file.

Gears

1. Inspect all gears and, if necessary, replace any that are worn or damaged.
2. Check the first and reverse sliding gear to make sure it slides freely on clutch sleeve.
3. Check the clutch sleeve to see that it slides freely on mainshaft.

Reverse Idler Gear Bushings

The bushings used in the idler gear are pressed into the gear then peened into holes in the bores to lock them into place, and are accurately bored with special diamond boring tools. This insures the positive alignment of the bushings and their shafts, as well as proper meshing of the gears. Because of the high degree of accuracy to which these parts are machined, the bushings are not serviced separately.

Check bushings for excessive wear by using a narrow feeler gauge between the shaft and the bushing. The proper clearance is from .002" to .004".

Countergear Needle Bearings

All countergear needle bearings should be inspected closely and if excessive wear shows, they should all be replaced as well as the shaft.

Clutch Gear Bearing Replacement

As the clutch gear and bearing are removed as a unit, it will be necessary to drive the clutch gear out of the bearing if replacement of either the gear or the bearing is required.

To remove, simply place outer race of bearing in a vise and tap out clutch gear with a soft hammer (fig. 6D-14).

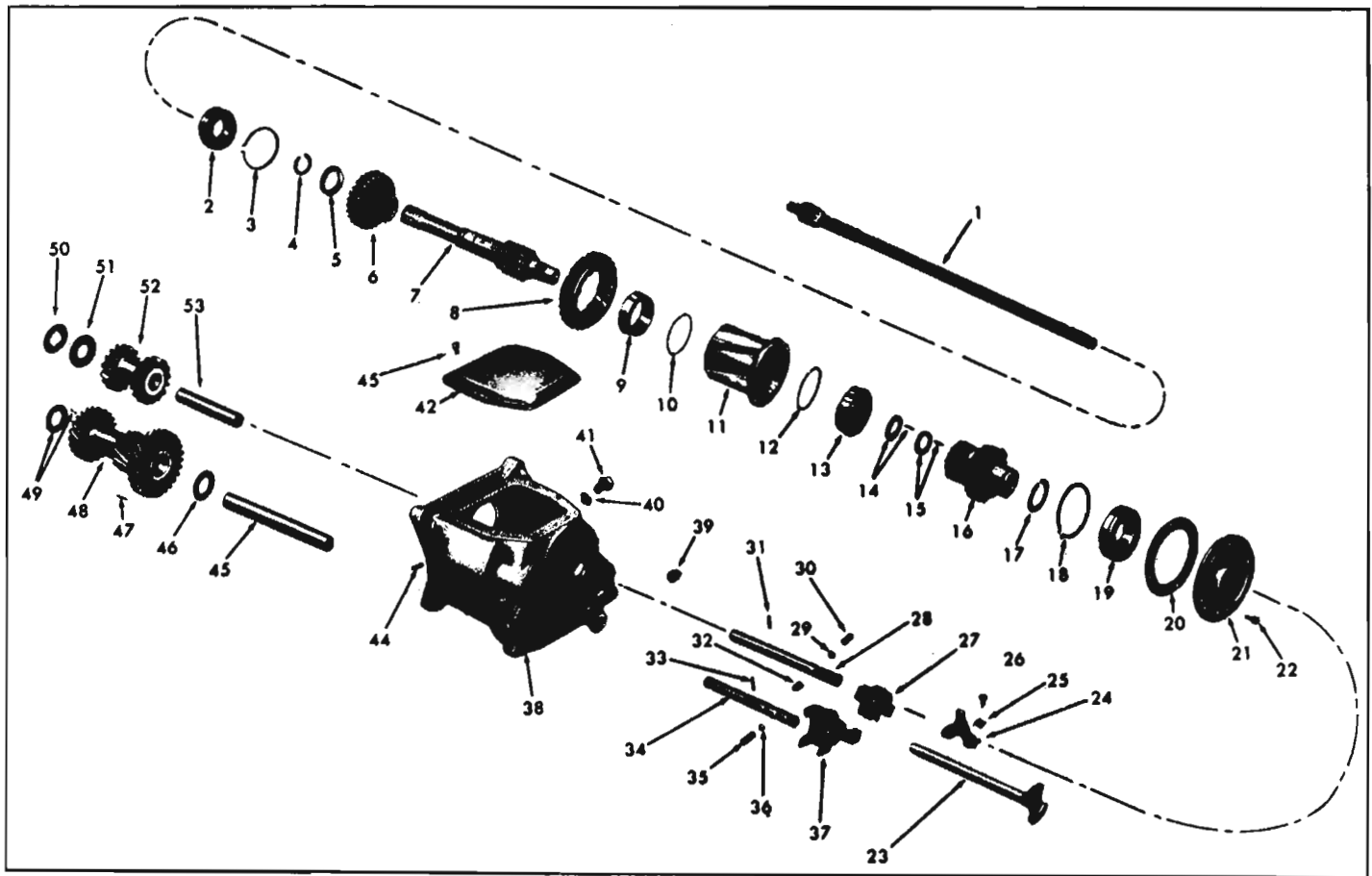

Fig. 6D-13—Manual Transmission—Exploded View

- | | | | |
|---|--|---|--|
| 1. Clutch Shaft | 16. Clutch Gear | 28. Second and Third Speed Shift Fork Shaft | 43. Top Cover Attaching Screws (8 Used) |
| 2. Main Shaft Bearing | 17. Snap Ring | 29. Detent Ball | 44. Reverse Idler Gear Shaft Lock Pin |
| 3. Main Shaft Bearing Retainer | 18. Clutch Gear Bearing Retaining Ring | 30. Detent Spring | 45. Counter Gear Shaft |
| 4. Snap Ring (Selective) | 19. Clutch Gear Bearing | 31. Roll Pin | 46. Counter Gear Front Bearings and Spacer |
| 5. Thrust Washer | 20. Front Cover Gasket | 32. Interlock | 47. Counter Gear Front Needle Bearings |
| 6. Second Speed Gear | 21. Front Cover | 33. Roll Pin | 48. Counter Gear |
| 7. Main Shaft | 22. Front Cover Mounting Bolt (4 Used) | 34. First and Reverse Shift Fork Shaft | 49. Counter Gear Rear Needle Bearings and Spacer |
| 8. First and Reverse Sliding Gear | 23. Manual Shift Lever | 35. Detent Spring | 50. Reverse Idler Gear Bearing Race |
| 9. Synchronizer Ring | 24. Shift Finger | 36. Detent Ball | 51. Reverse Idler Gear Bearing (Torrington) |
| 10. Energizing Spring | 25. Shift Finger Attaching Bolt Lock Tab | 37. First and Reverse Fork | 52. Reverse Idler Gear |
| 11. Second and Third Speed Clutch | 26. Shift Finger Attaching Bolt | 38. Transmission Case | 53. Reverse Idler Gear Shaft |
| 12. Energizing Spring | 27. Second and Third Speed Shift Fork | 39. Pipe Plug (2 Used) | |
| 13. Synchronizer Ring | | 40. Detent Cap Gasket | |
| 14. Clutch Gear Rear Bearings and Spacer | | 41. Detent Cap | |
| 15. Clutch Gear Front Bearings and Spacer | | 42. Top Cover | |

NOTE: There should be no problem removing bearing as tolerance minimum is zero clearance.

Installation of new bearing can be accomplished by tapping or pressing new bearing onto clutch gear with a suitable socket used on the bearing inner race.

Clutch Sleeve and Synchronizer Rings

1. Remove the first and reverse sliding gear.
2. Turn the synchronizer ring in the clutch sleeve until the ends of the synchronizer ring retainer can be seen through the slot in the clutch sleeve.

3. Using J-0932 expand the retainer into the counter-bore in the clutch sleeve. This raises the retainer from the groove in the ring so ring may be easily slipped out (fig. 6D-15).
4. Check the synchronizing cones for wear or for being loose in the clutch sleeve. If cones are damaged in any way, it will be necessary to replace the clutch sleeve assembly and both synchronizer rings. Clutch sleeve should be replaced if there is more than .030" end play between cone and snap ring.
5. Inspect the synchronizer rings for smoothness.

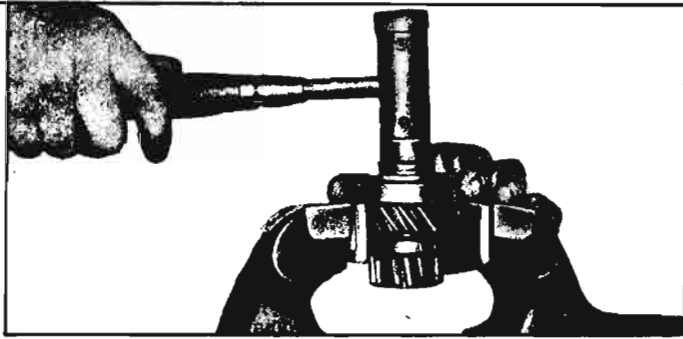

Fig. 6D-14—Removing Clutch Gear Bearing

6. Place the synchronizer rings in the synchronizing cones and check with thumbs to see that rings do not rock. Excessive rocking indicates a poor fit between the rings and cone, which will not permit proper synchronizing of gears during shifting.
7. Install the synchronizer ring retainers in the counterbores in the ends of the clutch sleeves.
8. Using J-0932 in slot in clutch sleeve, expand each retainer in the counterbore, lubricate each synchronizer ring with light oil and install in clutch sleeve.

NOTE: Make sure retainers seat in groove all



Fig. 6D-15—Removing Synchronizer Ring with J-932

the way around the rings so rings will turn freely.

9. Install the first and reverse sliding gear on the clutch sleeve.

Synchronizer Energizing Springs

1. It will be noticed upon examining these springs that one of the ends is slightly offset. Each spring must be assembled in its groove in the clutch gear and the second speed gear with the offset or locking end between the third and fourth teeth of either of the two banks of teeth on these gears, thus keeping the spring from turning in its groove (fig. 6D-16).
2. Under normal operation it should never be necessary to replace the energizing springs; however,

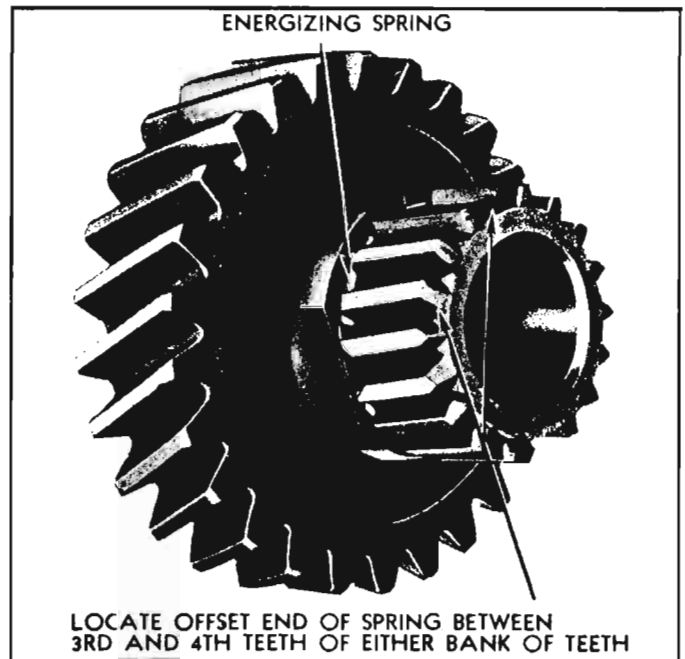

Fig. 6D-16—Position of Energizing Spring

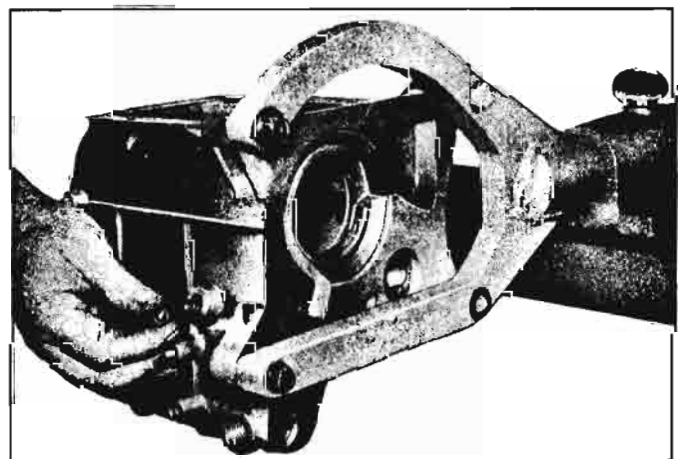

Fig. 6D-17—Installing Detent Spring and Ball for First and Reverse Shift Fork Shaft

should an energizing spring be removed for any reason, a new spring should be installed. The spring may be removed by slipping a thin blade under the spring and raising it sufficiently to slide it off over the clutch gear teeth.

CAUTION: Spring must be carefully installed so as not to expand it greater than the diameter of the clutch gear teeth as the spring will set.

ASSEMBLY OF TRANSMISSION

1. Mount transmission case in J-7896.
2. Lubricate manual control shaft with oil, then insert through seal in case. Position actuating finger and secure to shaft with two lock tabs and cap-screws. Bend lock tabs onto heads of screws.
3. Install detent spring and ball (fig. 6D-17) in that order in detent cavity. Tap ball and spring to insure the spring is resting on bottom of cavity.
4. Insert first and reverse fork shaft through case,

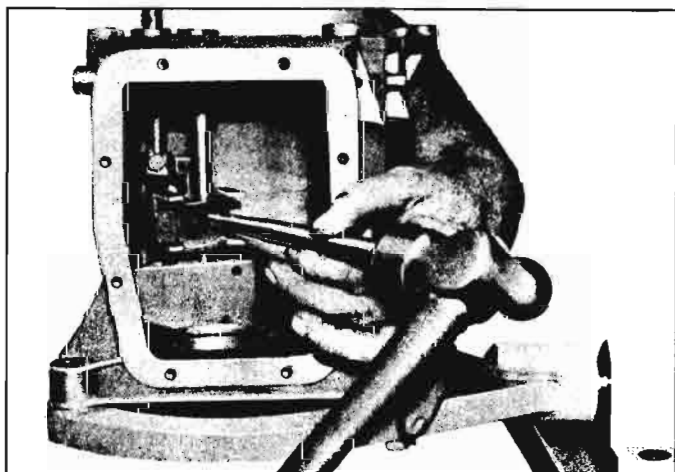

Fig. 6D-18—Installing First and Reverse Shift Fork

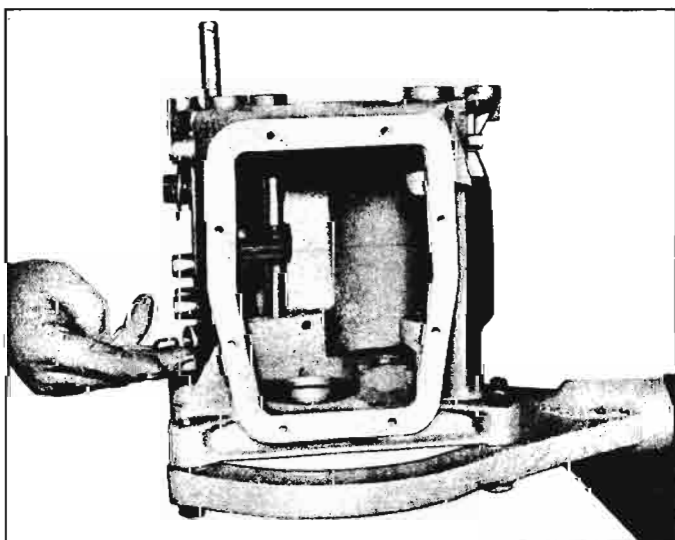

Fig. 6D-19—Installing Shift Forks Interlock

slip fork on shaft, and secure fork to shaft with roll pin (fig. 6D-18).

5. Install interlock in detent cavity (fig. 6D-19).
6. Insert second and third fork shaft through case and slip fork (fig. 6D-20) onto shaft. Twist shaft so its interlock groove is 90-degrees from the interlock, then fully insert shaft and twist the shaft so the interlock notch is engaged by the interlock. Now secure shift fork to shaft with roll pin.
7. Insert detent ball and spring for second and third shift fork, then install detent cavity cover and gasket.
8. Place some cup grease in the roller bearing area of each end of the countergear and install the 25 rollers in each end. The grease will hold the rollers in place while installing (fig. 6D-21).
9. Insert J-5777 in countergear.
10. Apply grease to bearing thrust washers and countergear thrust washer and place one of each at each end of countergear. Tab on each thrust washer should be positioned so as to align with notches in case.
11. Insert the countergear (with J-5777) in transmission case and rest it on bottom of case.
12. Lubricate and insert countergear in case, align countergear with shaft being sure thrust washer tabs engage case notches and tap shaft through,

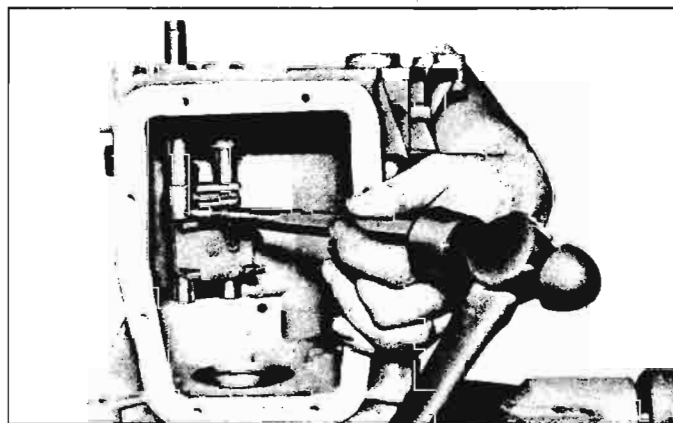

Fig. 6D-20—Installing Second and Third Shift Fork

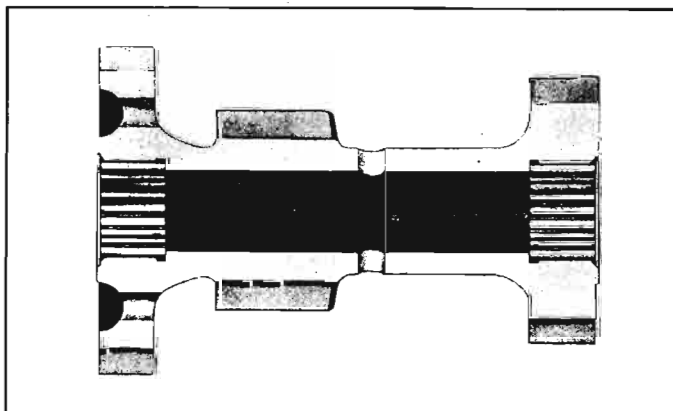

Fig. 6D-21—Countergear Bearings Installed

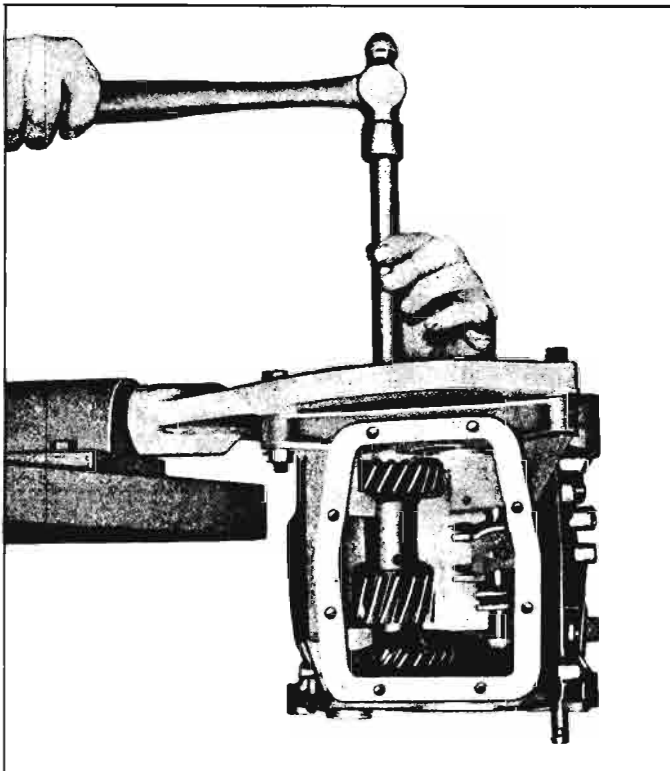

Fig. 6D-22—Installing Countershaft in Countergear

pushing assembly tool J-5777 out of case (fig. 6D-22). The shaft fit is a slight press at the front of the case. Tap the countershaft into the case until its higher step is flush with the rear face of the case. Stake the shaft in one place at the rear of the case (adjacent to the lower step of the countershaft) and at three places equally spaced at the front of the case.

NOTE: In the "Corvair", the final installed position of the flat on the countergear shaft is unimportant. The flat occurs only because the shaft is common to conventional production transmissions.

13. Coat thrust washer and the needle thrust bearing with grease and position them on reverse idler gear; needle bearing against end (rear) with chamfered gear teeth (fig. 6D-23). Coat bushings with transmission lubricant.
14. Place reverse idler gear assembly in position in case so thrust bearing is toward rear.
15. Install the reverse idler shaft from rear, making sure the lock pin hole in the shaft lines up with the hole in the case at the same angle (fig. 6D-23).
16. Use a new idler shaft lock pin and drive it in approximately $\frac{1}{16}$ " beyond flush with case.
17. Install mainshaft rear bearing in case by tapping on O.D. of bearing until bearing contacts retainer ring in case. Then expand retainer and tap bearing until retainer ring seats in bearing groove (fig. 6D-24).
18. Install sliding gear (4, fig. 6D-25) on second and

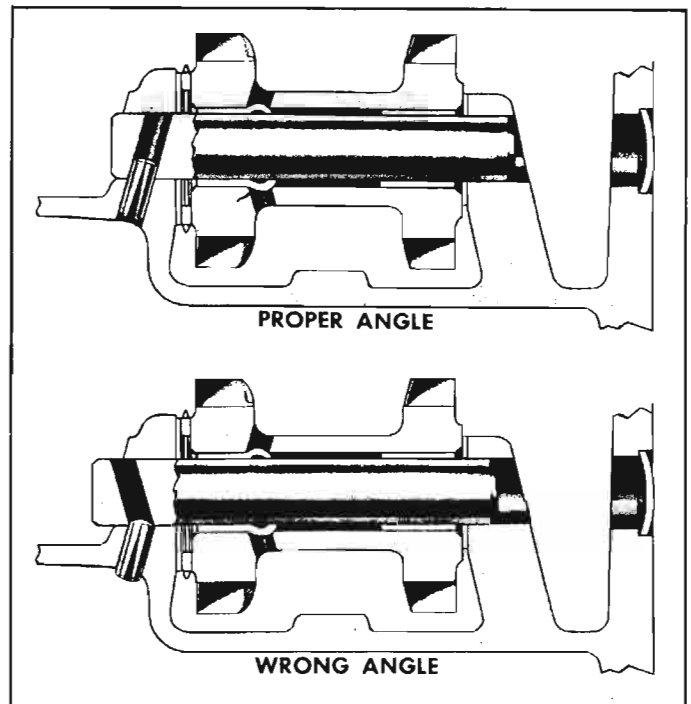

Fig. 6D-23—Reverse Idler Gear Installation Showing Lock Pin Alignment

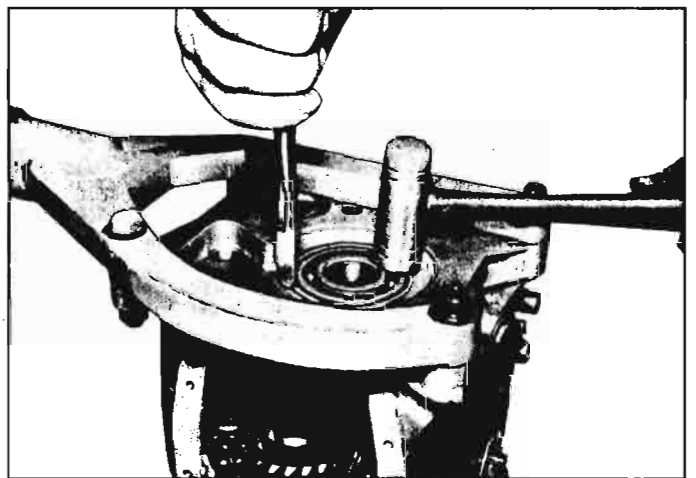

Fig. 6D-24—Installing Mainshaft Rear Bearing

- third speed clutch (3).
19. Install second speed gear (5, fig. 6D-25) in second and third speed clutch.
20. Place assembled second and third speed clutch, sliding gear and second speed gear in case (fig. 6D-26).
21. From the front, insert the mainshaft through the bores of the second and third speed clutch and second speed gear, then install the thrust washer on the mainshaft with its oil grooves toward the gear.
22. Tap the front of the mainshaft until the ring groove is accessible behind the rear bearing and install the snap ring.

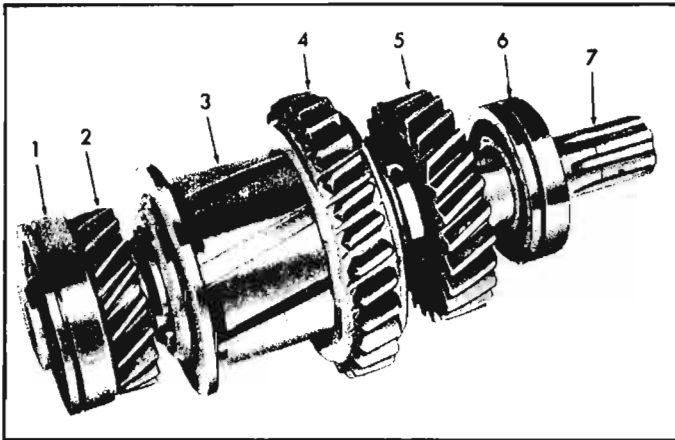

Fig. 6D-25—Mainshaft Components

- | | |
|-----------------------------------|----------------------|
| 1. Clutch Gear Bearing | 5. Second Speed Gear |
| 2. Clutch Gear | 6. Mainshaft Bearing |
| 3. Second and Third Speed Clutch | 7. Mainshaft |
| 4. First and Reverse Sliding Gear | |

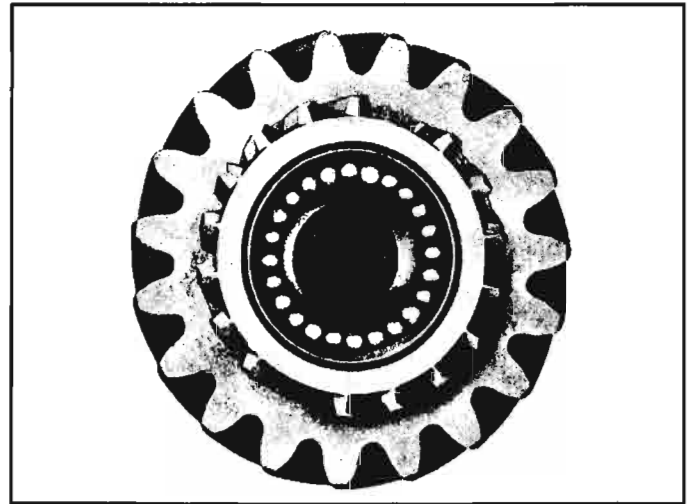

Fig. 6D-27—Mainshaft Pilot Bearings in Clutch Gear

23. Check fit of snap ring at front of mainshaft (installed in previous step) by inserting feeler stock between snap ring and bearing inner race. Final end clearance must be .004" maximum, therefore change to applicable thickness thrust washer if original does not meet this limit. Washers are available in four (4) thicknesses, ranging from .086" to .097".
24. Place some cup grease in the mainshaft pilot hole of the clutch gear and install roller bearings and small spacer. Then install the large spacer and remaining roller bearings (fig. 6D-27).
25. Align the synchronizer lands with the clutch gear blank teeth (fig. 6D-27). Install smaller snap ring in clutch gear.

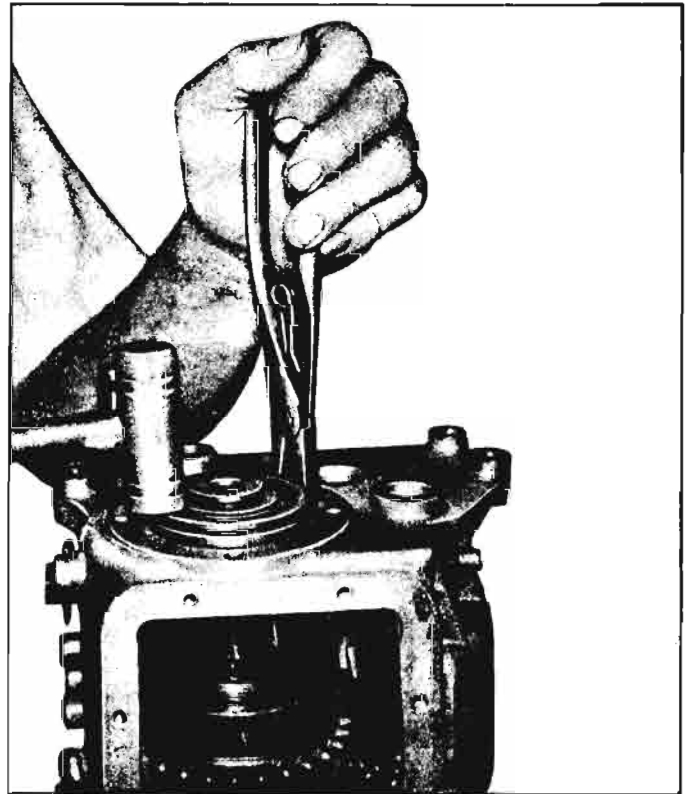

Fig. 6D-28—Installing Clutch Gear Bearing

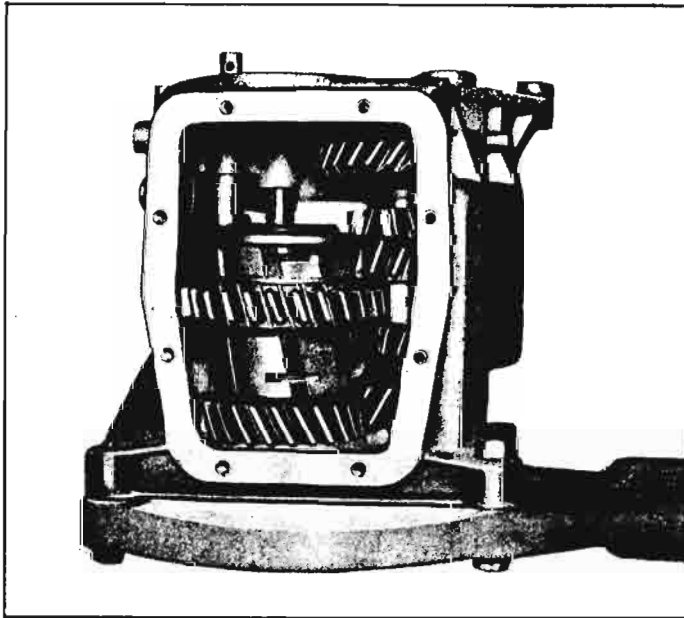

Fig. 6D-26—Second and Third Speed Clutch, Sliding Gear and Second Speed Gear Installed

26. Tap the clutch gear bearing into the case, then open retainer ring and fully seat bearing as indicated by seating of the retainer ring in the bearing groove (fig. 6D-28).
27. Install the front cover plate and gasket and secure with four screws.
28. Install top cover and gasket and secure with eight screws.
29. Install expansion plugs in the case openings at the rear of the manual shift shaft and reverse idler gear.

TROUBLES AND REMEDIES

Symptom and Probable Cause

Probable Remedy

Slips Out of High Gear

- a. Transmission loose on differential carrier.
- b. Control linkage does not work freely, binds.
- c. Does not fully engage.
- d. Damaged mainshaft pilot bearing.
- e. Clutch gear bearing retainer broken or loose.
- f. Dirt between transmission case and differential carrier.

- a. Tighten mounting bolts.
- b. Adjust and free up shift linkage. Torque reactions of engine should not cause the lever on transmission to move. The movement of transmission with respect to body should be transferred to the control linkage.
- c. Measure length of engagement pattern on clutching teeth. If less than $\frac{7}{16}$ " , check for bent levers, shifter shafts, detent cam plates, control rods and other shift linkage. Replace or straighten defective parts.
- d. Replace pilot bearing.
- e. Replace clutch gear bearing retainer.
- f. Clean mating surfaces.

Slips Out of Low and/or Reverse

- a. First and/or Reverse gears damaged from operating at part engagement.
- b. Improper mated splines on inside of first and reverse gear and/or external spline on 2nd and 3rd clutch sleeve.
- c. Improperly adjusted linkage.

- a. Determine cause, for example, worn shift fork & control lever or rod interference. Replace worn or bent parts.
- b. Replace 2nd or 3rd speed clutch sleeve and/or first, and reverse sliding gear. Possible correction is to change index of gear on clutch sleeve approximately 180° and/or turning the rear side of first and reverse gear to the front of the transmission.
- c. Adjust linkage.

Noisy in All Gears

- a. Insufficient lubricant.
- b. Worn countergear bearings.
- c. Worn or damaged clutch gear and countershaft drive gear.
- d. Damaged clutch gear or mainshaft ball bearings.
- e. Damaged speedometer gears.

- a. Fill to correct level.
- b. Replace countergear bearings and shaft.
- c. Replace worn or damaged gears.
- d. Replace damaged bearings.
- e. Replace damaged gears.

Noisy in High Gear

- a. Damaged Clutch gear bearing.
- b. Damaged mainshaft bearing.

- a. Replace damaged bearing.
- b. Replace damaged bearing.

Noisy in Neutral with Engine Running

- a. Damaged clutch gear bearing.
- b. Damaged mainshaft pilot bearing roller.

- a. Replace damaged bearing.
- b. Replace damaged bearing roller.

Noisy in All Reduction Gears

- a. Insufficient lubricant.
- b. Worn or damaged clutch gear or counter drive gear.

- a. Fill to correct level.
- b. Replace faulty or damaged gears.

Symptom and Probable Cause	Probable Remedy
Noisy in Second Only	
a. Damaged or worn second speed constant mesh gears.	a. Replace damaged gears.
b. Worn or damaged countergear rear bearings.	b. Replace countergear bearings and shaft.
Noisy in Low and Reverse Only	
a. Worn or damaged first and reverse sliding gear.	a. Replace worn gear.
b. Damaged or worn low and reverse countergear.	b. Replace countergear assembly.
Noisy in Reverse Only	
a. Worn or damaged reverse idler.	a. Replace reverse idler.
b. Worn reverse idler bushings.	b. Replace reverse idler.
c. Damaged or worn reverse countergear.	c. Replace countergear assembly.
Excessive Backlash in Second Only	
a. Second speed gear thrust washer worn.	a. Replace thrust washer.
b. Mainshaft rear bearing not properly installed in case.	b. Replace bearing or case, as necessary.
c. Worn countergear rear bearing.	c. Replace countergear bearings and shaft.
Excessive Backlash in All Reduction Gears	
a. Worn countergear bushings.	a. Replace countergear.
b. Excessive end play in countergear.	b. Replace countergear thrust washers.
Leaks Lubricant	
a. Excessive amount of lubricant in transmission.	a. Drain to correct level.
b. Loose or broken clutch gear bearing cover.	b. Tighten or replace cover.
c. Clutch gear bearing retainer gasket damaged.	c. Replace gasket.
d. Cover loose or gasket damaged.	d. Tighten cover or replace gasket.
e. Operating shaft seal leaks.	e. Replace operating shaft seal.
f. Idler shaft expansion plugs loose.	f. Replace expansion plugs.
g. Countershaft loose in case.	g. Replace case.

SPECIFICATIONS

All specifications for the three speed transmission are carried in Section 16 of this Manual.